

REMARKS

Claims 1-3, 6-14, 17-22, 35, 40-48, and 54-56 were previously pending for examination. Claims 1, 12, 35, 40, 41, 55, and 56 are currently amended. Claims 7, 8, 18, and 19 are currently canceled without prejudice or disclaimer. No new claims are currently added. Support for these amendments can be found, for example, in FIG. 2 and paragraphs [0059] and [0060] of the application as published (U.S. Patent Pub. No. 2007/0007214 A1). As a result, claims 1, 3, 6, 9-14, 17, 20-22, 35, 40-48, and 54-56 are currently pending for examination, with claims 1, 12, 35, 40, and 41 being independent claims. No new matter has been added.

Rejections under 35 U.S.C. § 112

Dependent claims 55 and 56 were rejected under 35 U.S.C. § 112, first paragraph. The Examiner asserts in the Office Action that “While the gas line 2 appears to be running through the header, there is no disclosure to support the claim limitation that it is integral with the header, or is placed among the plurality of porous membranes.” Without acceding to the correctness of this rejection, in order to advance prosecution, Applicants have amended dependent claims 55 and 56. Reconsideration and withdrawal of the rejection of dependent claims 55 and 56 under 35 U.S.C. § 112 is respectfully requested.

Rejections under 35 U.S.C. § 103

Heine in view of Shimizu

Claims 1-3, 6, 8-14, 17, 19-22, 35, 40-42, and 54-56 were rejected under 35 U.S.C. § 103(a) as being unpatentable over Heine et al. (US 6,126,819) (hereinafter “Heine”) in view of Shimizu et al. (US 5482625) (hereinafter “Shimizu”).

It is noted that claims 7, 8, 18, and 19 are canceled, rendering the rejection of these claims moot.

There is no *prima facie* case of obviousness of claims 1-3, 6, 9-14, 17, 20-22, 35, 40-48, and 54-56 over Heine in view of Shimizu. The asserted combination of Heine and Shimizu fails to disclose or suggest each and every element of any of these claims. Further, one of ordinary skill in the art would not have been motivated to have combined Heine and Shimizu *ab initio*.

Heine in view of Shimizu fails to disclose or suggest a membrane module comprising a plurality of porous membranes mounted in a pot supported by a header wherein a plurality of distribution apertures are defined in said pot

Heine fails to disclose or suggest “A membrane module comprising: a plurality of porous membranes extending in an array and mounted, at least at one end, in a pot supported by a header [wherein] a plurality of distribution apertures [are] defined in said pot” as recited in independent claim 1, as amended. Heine discloses passages 221 formed in a closure element 22, however the closure element 22 is not “a pot supported by a header” in which “a plurality of porous membranes [are] mounted.” Rather, closure element 22 appears to enclose Heine’s hard elastic joining means 224 and soft elastic mounting means 225 in which the membrane elements 13 are mounted. If Heine discloses any “pot supported by a header” in which “a plurality of porous membranes [are] mounted,” which Applicants do not concede, this pot might be either one or both of the hard elastic joining means 224 or the soft elastic mounting means 225, but could not be the closure element 22. This is at least because the closure element 22 is not a pot supported by a header. Heine does not disclose or suggest any distribution apertures formed in either the hard elastic joining means 224 or the soft elastic mounting means 225 and thus cannot disclose or suggest “A membrane module comprising: a plurality of porous membranes extending in an array and mounted, at least at one end, in a pot supported by a header [wherein] a plurality of distribution apertures [are] defined in said pot” as recited in independent claim 1.

One of ordinary skill in the art would not have been motivated to modify Heine to include distribution apertures in the hard elastic joining means 224 or the soft elastic mounting means 225 as such distribution apertures would intersect Heine’s permeate collection spaces 220 located below the hard elastic joining means 224. This would fluidly connect the permeate collection spaces 220 to the liquid media 11, contaminating any collected permeate with dirty liquid media 11. This would render Heine’s apparatus unable to perform the function of separating permeate from the liquid media.

Shimizu cannot cure the failure of Heine to disclose or suggest “A membrane module comprising: a plurality of porous membranes extending in an array and mounted, at least at one end, in a pot supported by a header [wherein] a plurality of distribution apertures [are] defined in said pot” as recited in independent claim 1. This is because Shimizu does not disclose porous membranes mounted in any pot. Rather, Shimizu discloses plate-like, rigid membrane cartridges 110 including filtration membranes “adhered to [a] membrane supporting plate 118 with an adhesive or welded by heat or ultrasonic wave to [a] membrane supporting net 119” or fixed to a membrane supporting plate by means of adhesion or fusion. (Shimizu at Col. 2, lines 29-44; Col. 7, lines 7-11; Col. 10, lines 61-63; FIGS. 4 and 5 and the description thereof.)

The failure of the filtration module of Heine to disclose “a pot supported by a header” in which “a plurality of porous membranes [are] mounted [wherein] a plurality of distribution apertures [are] defined in said pot” results in a membrane filtration module with a significantly different structure and feed flow characteristics than the membrane module claimed in independent claim 1. These differences patentably distinguish the claimed membrane module from that of Heine. For example, as illustrated in the figure below (FIG. 5 of Heine, modified to indicate spacings), the membrane module of Heine includes a horizontal spacing between the exits of the passages 221 and the membrane elements 13. Such spacings are not present in the claimed membrane module. This spacing may make it less likely that freshly introduced liquid media or aeration gas flowing through the module would reach the portions of the membrane elements 13 near the point where the membrane elements emerge from their support means, thus producing less efficient filtration and/or scrubbing than the membrane module claimed. The horizontal spacing between the exits of the passages 221 and the membrane elements 13 could also induce turbulence in the flow of feed through the module, which could increase the amount of energy required to push the liquid media through the module.

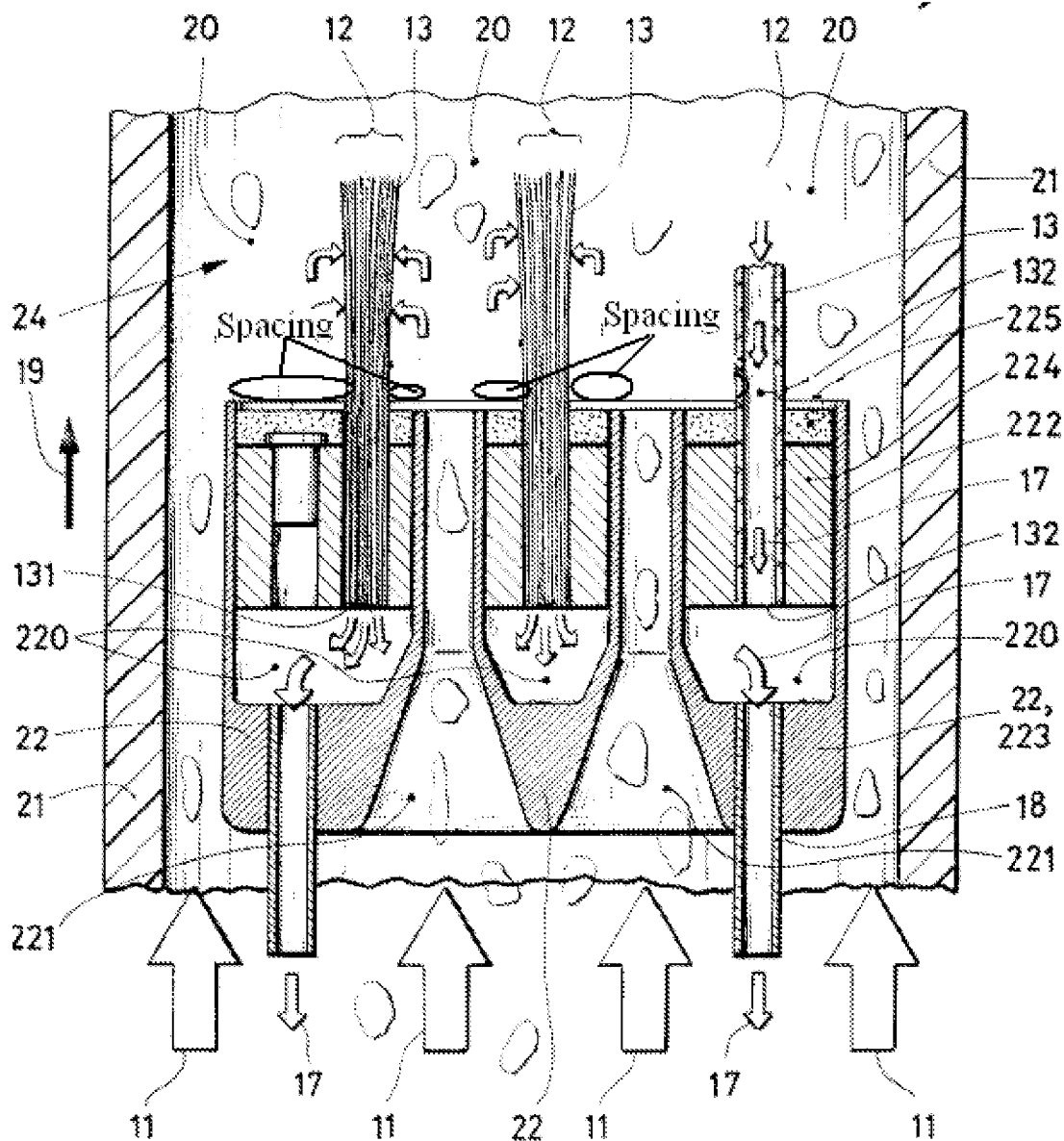

Heine in view of Shimizu fails to disclose or suggest a membrane module including a clover-type manifold coupled to a header, and a chamber positioned below, and connected to, said clover-type manifold

Heine fails to disclose or suggest a membrane module including “a clover-type manifold coupled to [a] header; and a chamber positioned below, and connected to, said clover-type manifold” as recited in independent claim 1, as amended. Shimizu also fails to disclose or suggest “a clover-type manifold” and thus cannot cure the failure of Heine to disclose or suggest this.

One of ordinary skill in the art would not have been motivated, upon a reading of Heine, to modify the membrane module of Heine to include “a clover-type manifold coupled to [a] header; and a chamber positioned below, and connected to, said clover-type manifold.” Heine discloses in multiple places that it is a perceived advantage to provide a membrane filtration module that does not require flow of feed liquid to be redirected in order to reduce the energy required to operate the membrane module. (Heine at Col. 2, lines 9-11 “All these apparatus have a disadvantage in that, because the flow through the apparatus must be redirected, they generate a relatively high hydrodynamic resistance”; Col. 2, lines 56-61 “Another advantage of the arrangement according to the invention is that, because the flow passages are linear, there is no need for spacing elements, guide elements or any other elements which would affect in any way the flow of the medium to be separated on its way through the apparatus”; Col. 2, line 67- Col. 3, line 5 “As a result of the essentially linear flow passages without any deflections, the hydraulic resistance for the medium passing through the apparatus is low. Consequently, the required pressure for conducting the raw medium through the apparatus is relatively low so that also the energy requirements herefor are low.”)

As illustrated in the figure below (an amended reproduction of FIG. 2 of the present application), the clover-type manifold claimed causes a deflection of feed liquid flowing through the filtration module. As such, one of ordinary skill in the art would not have been motivated to have included a clover-type manifold in the membrane filtration module of Heine as this would run counter to the teaching of Heine of the advantages of avoiding the deflection of feed liquid in a membrane module. The clover-type manifold claimed patentably distinguishes the claimed filtration module from that of Heine because it provides for significant structural differences between the two. For example, the clover-type manifold allows for multiple membrane modules to be mounted above a single mixing chamber, something that could not be performed using the membrane module disclosed in Heine.

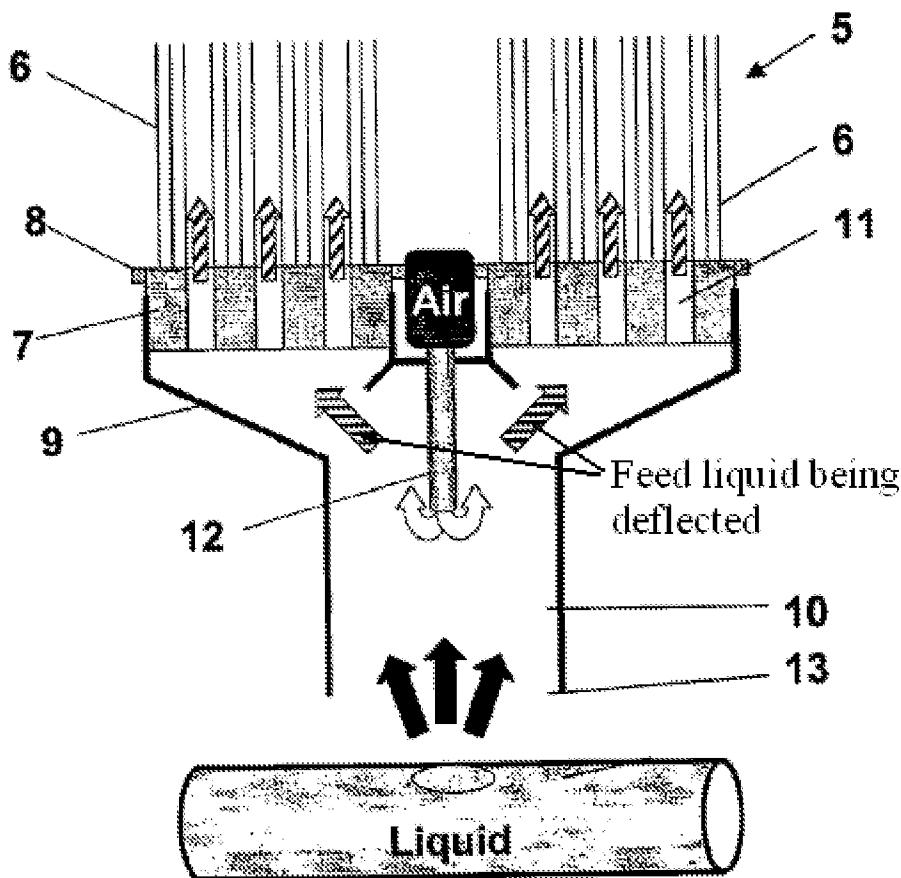

Heine in view of Shimizu fails to disclose or suggest a gas inlet constructed and arranged to introduce gas into a mixing chamber in a downward direction from above the open base end, said gas fed from above and through said clover-type manifold

Heine fails to disclose or suggest “a gas inlet constructed and arranged to introduce gas into [a mixing] chamber in a downward direction from above the open base end, said gas fed from above and through said clover-type manifold” as recited in independent claim 1, as amended. As discussed above, Heine fails to disclose or suggest any clover-type manifold, and thus cannot disclose or suggest gas being “fed from above and through said clover-type manifold.” Shimizu cannot cure the failure of Heine to disclose or suggest this element of independent claim 1 because Shimizu also fails to disclose any clover-type manifold. Further, the gas diffuser 504 of Shimizu feed gas into the filtration module through tubes entering the filtration module from a horizontal direction, not from above. (Shimizu FIG. 24.) To modify the gas diffuser 504 of Shimizu to introduce gas from above would require a fundamental change to the design and operation of the filtration module of Shimizu. There is no suggestion in Heine or

Shimizu that would lead one of ordinary skill in the art to make such a modification to the filtration module of Shimizu.

A membrane module including “a gas inlet constructed and arranged to introduce gas into [a mixing] chamber in a downward direction from above the open base end, said gas fed from above and through [a] clover-type manifold” patentably distinguishes over the asserted combination of Heine and Shimizu. To provide an air inlet for introducing air into a mixing chamber in a downward direction from above the open base end of a membrane filtration module as claimed provides for different operational characteristics for a membrane module than the arrangement of air inlets disclosed in Shimizu. For example, in the membrane module claimed, the air inlet has less cross sectional area in the direction of feed flow than does the air diffuser 504 of Shimizu. This provides for less hardware present in the flow path of feed liquid into the module, which may result in lower flow resistance and energy requirements for operating the module.

Heine and Shimizu would not have been combined in the manner asserted by one of ordinary skill in the art. As discussed above, Heine stresses the importance of avoiding placing objects in the flow path of feed through the filtration module which might deflect the flow path of feed through the module. Including the air diffuser 504 of Shimizu in the central passage 250 of Heine, would, however, do just that – the air diffuser 504 is an object which would partially block the flow of feed through the module and thus increase the feed flow resistance and the energy required to pump feed through the module. As such, Heine teaches away from including an air diffuser such as that disclosed in Shimizu in the filtration module disclosed, and one of ordinary skill in the art would not have been motivated to make such a combination of Heine and Shimizu.

Because the asserted combination of Heine and Shimizu cannot disclose or suggest each and every claim element of independent claim 1 and because Heine and Shimizu would not have been combined in the manner asserted by one of ordinary skill in the art, independent claim 1 and the claims that depend therefrom cannot be obvious over Heine in view of Shimizu. Independent claims 12, 35, 40, and 41 each include at least one of the claim elements of independent claim 1 discussed above that cannot be obvious over Heine in view of Shimizu, and thus independent claims 12, 35, 40, and 41 and the claims that depend from these claims are patentable over the asserted combination of Heine and Shimizu for at least the same reasons.

Accordingly, reconsideration and withdrawal of the rejection of claims 1-3, 6, 9-14, 17, 20-22, 35, 40-48, and 54-56 under 35 U.S.C. § 103 over Heine in view of Shimizu is respectfully requested.

Zha in view of Shimizu

Claims 1-3, 6-14, 17-22, 35, 40-48, and 54-56 were rejected under 35 U.S.C. § 103(a) over Zha et al. (US 2001/0047962) (hereinafter “Zha”) in view of Shimizu.

It is noted that claims 7, 8, 18, and 19 are canceled, rendering the rejection of these claims moot.

There is no *prima facie* case of obviousness of claims 1-3, 6, 9-14, 17, 20-22, 35, 40-48, and 54-56 over Zha in view of Shimizu. The asserted combination of Zha and Shimizu fails to disclose or suggest each and every element of any of these claims. Further, one of ordinary skill in the art would not have been motivated to have combined Zha and Shimizu *ab initio*.

Zha discloses a membrane filtration module in which a “venturi device 12 intakes gas through inlet 13 [and] mixes or entrains the gas with liquid flowing through feed inlet 14” (Zha at paragraph [0041]). In all of the embodiments of the membrane filtration module disclosed in Zha, an air inlet integral to a wall of a venturi device 12 (Zha at FIG.1) or jet assembly chamber 16, 57 (Zha at FIGS. 2 and 9) is disclosed as introducing air from a side of the membrane filtration module and perpendicular to a flow of feed from a feed inlet.

Zha does not disclose or suggest any “clover-type manifold coupled to [a] header; and a chamber positioned below, and connected to, said clover-type manifold” or “a gas inlet constructed and arranged to introduce gas into said chamber in a downward direction from above the open base end, said gas fed from above and through said clover-type manifold” as recited in independent claim 1, as amended. One of ordinary skill in the art would not have been motivated to modify the structure of the membrane filtration module of Zha to include these features because doing so would have required a fundamental alteration to the structure and method of operation of the membrane filtration module disclosed.

Shimizu cannot cure the failure of Zha to disclose or suggest these elements of independent claim 1, because, as discussed above, Shimizu also does not disclose or suggest any clover-type manifold, or any gas inlet which directs gas into a mixing chamber from above and through any clover-type manifold.

Further, one of ordinary skill in the art would not have been motivated to have combined Zha with Shimizu in the manner asserted or to have modified Zha to include “a gas inlet constructed and arranged to introduce gas into [a mixing] chamber in a downward direction from above the open base end [of the mixing chamber].”

Zha discloses that an advantage of the filtration module disclosed is to make it “possible to create gas bubbles and aerate the system without a blower” because “[w]hen a motive fluid passes through a venturi it generates a vacuum to draw the gas into the liquid flow and generate gas bubbles therein” (Zha at paragraphs [0041] and [0045]). “By using a venturi device or the like, it is possible to generate gas bubbles to scrub membrane surfaces without the need for a pressurized gas supply such as a blower [which] lowers the cost of operation [of the filtration system].” (Zha at paragraph [0045].) Zha further discloses that methods wherein “a gas is injected, usually by means of a pressurised blower, into a liquid system where a membrane module is submerged to form gas bubbles” suffer from several disadvantages. These methods “consume[] large amounts of energy, possibly form[] mist or froth flow reducing effective membrane filtration area, and may be destructive to membranes. Moreover, in an environment of high concentration of solids, the gas distribution system may gradually become blocked by dehydrated solids or simply be blocked when the gas flow accidentally ceases.” (Zha at paragraph [0004].)

One of ordinary skill in the art would not have been motivated upon a reading of Zha to have replaced the venturi device of Zha with the air diffuser of Shimizu as this would have negated the benefits of using a venturi device disclosed in Zha. Zha acknowledges that gas may be injected by means of a blower “into a liquid system where a membrane module is submerged to form gas bubbles” as is disclosed in Shimizu, however disparages such a method and discloses that such a method gives rise to numerous disadvantages. One of ordinary skill in the art would not have modified Zha as asserted in the Office Action because this would have resulted in the disadvantages disclosed in Zha without providing any advantage

Because the asserted combination of Zha and Shimizu cannot disclose or suggest each and every claim element of independent claim 1 and because Zha and Shimizu would not have been combined in the manner asserted by one of ordinary skill in the art, independent claim 1 and the claims that depend therefrom cannot be obvious over Zha in view of Shimizu. Independent claims 12, 35, 40, and 41 each include at least one of the claim elements of independent claim 1 discussed above that cannot be obvious over Zha in view of Shimizu, and

thus independent claims 12, 35, 40, and 41 and the claims that depend from these claims are patentable over the asserted combination of Zha and Shimizu for at least the same reasons. Accordingly, reconsideration and withdrawal of the rejection of claims 1-3, 6, 9-14, 17, 20-22, 35, 40-48, and 54-56 under 35 U.S.C. § 103 over Zha in view of Shimizu is respectfully requested.

Zha and/or Heine in view of Shimizu and Henshaw

Claims 1-3, 6-14, 17-22, 35, 40-48, and 54-56 were rejected under 35 U.S.C. § 103(a) over Zha and/or Heine in view of Shimizu, and further in view of Henshaw (US 5,783,083).

It is noted that claims 7, 8, 18, and 19 are canceled, rendering the rejection of these claims moot.

There is no *prima facie* case of obviousness of claims 1-3, 6, 9-14, 17, 20-22, 35, 40-48, and 54-56 over Zha and/or Heine in view of Shimizu, and further in view of Henshaw. The asserted combination of Zha and/or Heine, Shimizu and Henshaw fails to disclose or suggest each and every element of any of these claims. Further, one of ordinary skill in the art would not have been motivated to have combined these references *ab initio*.

The Examiner relies on Henshaw for teaching a “plurality of submerged membrane modules arranged in manifolds to have enlarged capacity treatment systems.” Even if Henshaw discloses this, Henshaw fails to cure the defect of Zha and/or Heine in view of Shimizu discussed above to disclose or suggest each and every claim element of any of independent claims 1, 12, 35, 40, and 41 and the claims that depend from these claims. For example, the asserted combination of Zha and/or Heine, Shimizu and Henshaw fails to disclose or suggest a “clover-type manifold coupled to [a] header; and a chamber positioned below, and connected to, said clover-type manifold” or “a gas inlet constructed and arranged to introduce gas into said chamber in a downward direction from above the open base end, said gas fed from above and through said clover-type manifold” as recited in independent claim 1 or the claim elements similar to these which are recited in independent claims 12, 35, 40, and 41.

The reasons why one of ordinary skill in the art would not have been motivated to have combined Zha and/or Heine with Shimizu are discussed above. These reasons apply equally well to the asserted combination of Zha and/or Heine, Shimizu and Henshaw.

As such, each of claims 1-3, 6, 9-14, 17, 20-22, 35, 40-48, and 54-56 is patentable the asserted combination of Zha and/or Heine, Shimizu and Henshaw. Accordingly, reconsideration

and withdrawal of the rejection of claims 1-3, 6, 9-14, 17, 20-22, 35, 40-48, and 54-56 under 35 U.S.C. § 103 over Zha and/or Heine, Shimizu and Henshaw is respectfully requested.

Provisional Double Patenting Rejection

Claims 1-22, 35, 40-48, and 54-56 were provisionally rejected on the ground of non-statutory obviousness-type double patenting as being unpatentable over the claims in co-pending Application No. 11/025,418 in view of Shimizu. Applicants respectfully disagree that any of claims 1-22, 35, 40-48, and 54-56 of the instant application should be rejected on the ground of obviousness-type double patenting. Notwithstanding this traversal, Applicants will submit a terminal disclaimer with respect to co-pending Application No. 11/025,418 once the instant claims are deemed allowable.

CONCLUSION

Applicants respectfully request reconsideration of the claims in view of the foregoing amendments and remarks. The application as presented is in condition for allowance. An early and favorable action is respectfully requested. If the Examiner believes, after this Response, that the application is not in condition for allowance, the Examiner is invited to call Applicants' representative at the telephone number listed below.

If this Response is not considered timely filed and if a request for an extension of time is otherwise absent, Applicants hereby request any necessary extension of time. If there is a fee occasioned by this response, including an extension fee that is not covered by an enclosed payment, please charge any deficiency to Deposit Account No. 50/2762 (Ref. No. M2019-7027US).

Respectfully submitted,
Fufang Zha et al., *Applicants*

By: /Gregory K. Gerstenzang/
Peter C. Lando, Reg. No. 34,654
Gregory K. Gerstenzang, Reg. No. 59,513
LANDO & ANASTASI, LLP
Riverfront Office Park
One Main Street
Cambridge, MA 02142
Telephone: 617-395-7019
Facsimile: 617-395-7070

Siemens Docket No. 2002P87059WOUS
Memcor Docket No.: IPD-C335-US
LL-A Docket No. M2019-7027US